



# INSTRUCTION BULLETIN

No. 9015117  
Machine: M17  
Published: 07-2016  
Rev. 00

**NOTE: DO NOT DISCARD the Parts List from the Instruction Bulletin. Place the Parts List in the appropriate place in the machine manual for future reference. Retaining the Parts List will make it easier to reorder individual parts and will save the cost of ordering an entire kit.**

*NOTE: Numbers in parenthesis ( ) are reference numbers for parts listed in Bill of Materials.*

Installation instructions for **kit number 9015077**

## SYNOPSIS:

This kit contains the parts needed to replace the long hopper chain on M17 sweeper- scrubbers. Please follow step-by-step instructions.

## SPECIAL TOOLS / CONSIDERATIONS: NONE

(Estimated time to complete: 1 hour)

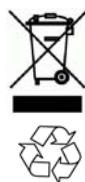

### PROTECT THE ENVIRONMENT

Please dispose of packaging materials, used machine components such as batteries and fluids in an environmentally safe way according to local waste disposal regulations.

Always remember to recycle.

## PREPARATION:

1. Stop the machine a clean level surface and set the parking brake.
2. Raise the hopper and roll the hopper out enough to fully access the left lift arm cover and all hardware securing the left lift arm cover to the machine. (Fig. 1)



**WARNING: Lift arm pinch point. Stay clear of hopper lift arms.**

3. Turn off the machine and remove the key.
4. Engage the hopper support bar.



**WARNING: Raised hopper may fall. Engage hopper support bar.**

5. Remove the left lift arm cover from the machine. Set the cover and three SEMS M8 hex screws aside. (Fig. 1)
6. Disengage the hopper support bar, turn on the machine, completely lower the hopper, turn off the machine, and remove the key.

**FOR SAFETY: Before leaving or servicing machine, stop on level surface, turn off machine, and remove key.**

7. Use a hoist, jack, or stands to support the hopper into the rolled in position / prevent hopper from rotating.

**INSTALLATION:**

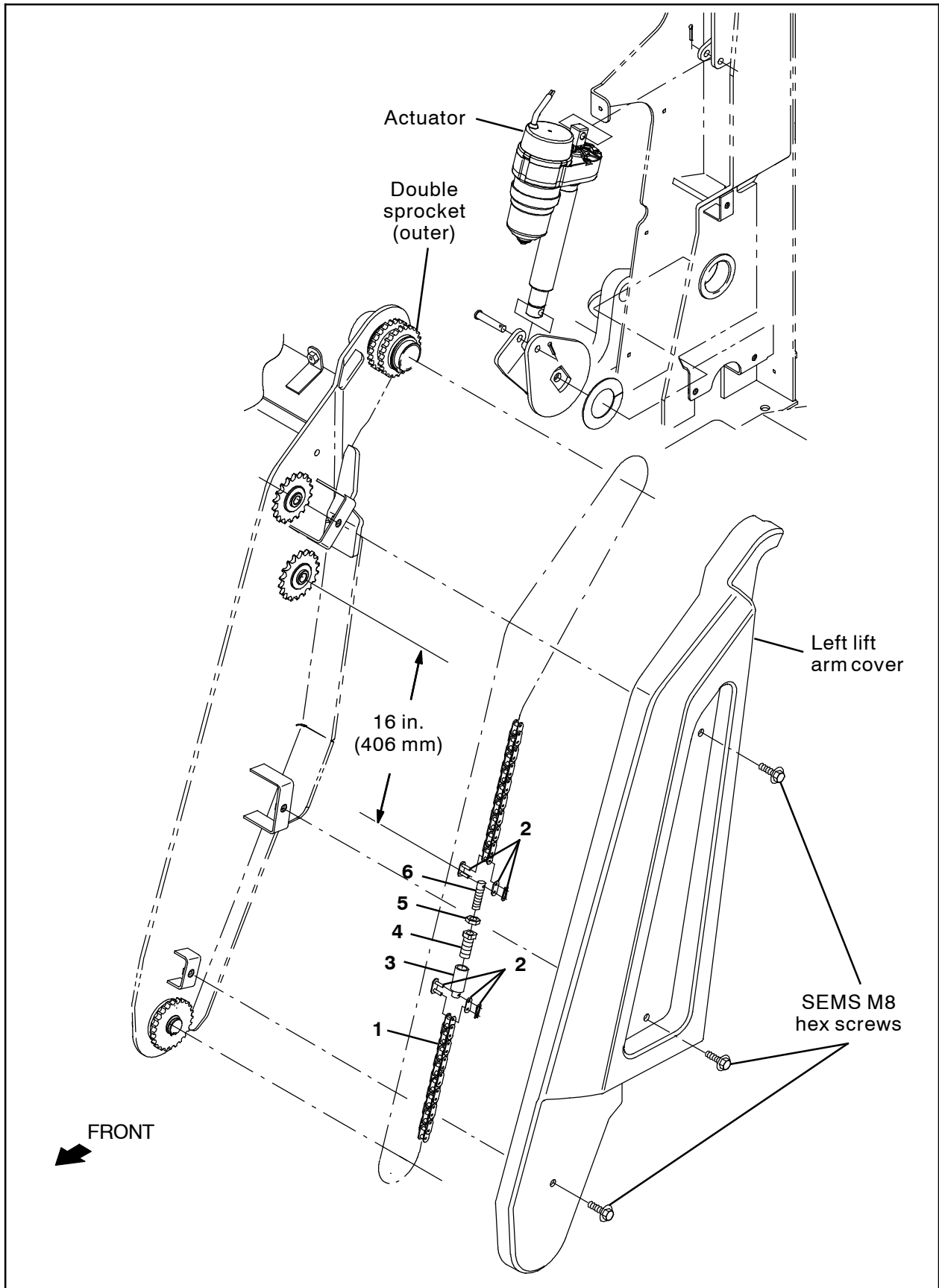

**FIG. 1**

1. Remove the existing chain from the machine. Discard the chain and all chain components. (Fig. 1)
2. Use one chain link assembly (2) to install the pivot (6) onto the chain (1). (Fig. 1)
3. Thread the M10 jam nut (5) onto the pivot (6). (Fig. 1)
4. Use the remaining chain link assembly (2) to install the ear (3) onto the chain (1). (Fig. 1)
5. Thread the housing (4) into the ear (3). (Fig. 1)
6. Install the chain assembly (1) onto the double sprocket where the removed chain was previously located. (Fig. 1)
7. Route the chain assembly around the other sprockets. (Fig. 1)
8. Position the chain assembly (1) tensioner so there there is 16 in. (406 mm) between the center of the sprocket and the end of the tensioner assembly with the pivot (6). (Fig. 1)
9. Thread the housing (4) onto the pivot (6). (Fig. 1)
10. Tighten the housing (4) onto the pivot (6) so the chain assembly (1) does not hang down. Do not over tighten the housing. It should be possible to move the chain approximately ½ in. (12.7 mm) perpendicularly with minimal effort on the slack side of the chain. (Fig. 1)
11. Tighten the M10 jam nut (5) against the housing (4). (Fig. 1)
12. Turn on and test the machine. Roll the hopper into the IN and OUT positions. The tensioner assembly should not go into any of the sprockets. Also observe the chain for binding. The chain should move freely on the sprockets. Make necessary adjustments.
13. When finished testing the machine, raise the hopper, engage the hopper support bar, turn off the machine, and remove the key.
14. Reinstall the left lift arm cover onto the machine.
15. Turn on the machine, disengage the hopper support bar, and lower the hopper.

---

**Bill Of Materials For Chain Kit, 40 X 181 Pitches, Afmkt [M17] - 9015077**

Ref.	Tennant Part No.	Description	Qty.
1	1216690	Chain, Rlr, 40 X 181 Pitches [M17]	1
2	07112	Link, Chain, Rlr, #40	2
3	386998	Ear	1
4	386997	Housing	1
5	32716	Nut, Hex, Jam, M10 X 1.5, SS	1
6	386999	Pivot	1

TENNANT COMPANY  
P. O. Box 1452  
Minneapolis, MN 55440-1452